

# (Almost) Everything You Need to Know About IRIG-B Time Sync

Quentin Griffiths

©Tekron International Limited 2017

## Table of Contents

IRIG-B.....	3
An Introduction .....	3
IRIG-B Modulation Types: .....	3
Carrier Frequency:.....	5
Coded Expressions: .....	5
IRIG-B Signal – Key Properties.....	8
Control Functions .....	11
AFNOR NFS 87-500 Extensions.....	11
C37.118.1 (superseded IEEE 1344 & C37.118) Extensions .....	12
Time Quality (TQ) .....	13
Continuous Time Quality (CTQ).....	13
Installation Recommendations .....	14
Cable type – Shielded Twisted Pair (STP) vs Coaxial .....	14
Terminating Resistor .....	15
a) DC Level Shift (DCLS).....	15
b) AM IRIG-B.....	15
IRIG-B00X Loading Recommendations.....	18
IRIG-B12X Loading Recommendations.....	19
Fibre Installations .....	20
Programmable Pulses.....	21
Summary .....	21

## IRIG-B

### An Introduction

The Inter-Range Instrument Group time code (or IRIG for short), is a range of standard time code formats which are used to transfer timing information (time, date, quality, etc) from a GPS/ Atomic clock to connected slave devices. With the IRIG standard first being drafted in 1956 and accepted in 1960, it's now a well-defined timing signal which has been widely adopted and improved over the years. The applications for IRIG's time codes range from synchronising substation automation systems to military communications and marine measurement equipment. With 6 defined formats to select from, IRIG have created a flexible and accurate timing format to work across all industries. The complete range of IRIG time code formats can be seen in figure 1.

Format:	
Format A	1 k pps
Format B	100 pps
Format D	1 ppm
Format E	10 pps
Format G	10 k pps
Format H	1 pps

Figure 1 – IRIG Formats sourced from IRIG Standard 200-04

The time code that is worth focusing on is the IRIG-B format. IRIG-B is the most common version used within the Power, industrial automation and control industries. Referring to figure 1, IRIG-B is a 1 kHz signal which contains 100 bits of data, each transmitted over a 10 ms time frame, taking a total time of 1 second for a complete transmission (what a mouthful...refer to table 1 for a summary).

Table 1 – IRIG-B time code

Code	Bit Rate	Bit Time	Bits per Frame	Frame Time	Frame Rate
IRIG-B	100 Hz	10 ms	100	1000 ms	1 Hz

Within IRIG-B there are a range of options available to make up the complete signal. The first is the modulation type.

### IRIG-B Modulation Types:

IRIG-B has three different modulation types;

0. **Direct Current Level Shift (DCLS)** – typically this is a 0-5 Vdc pulse width modulated signal, where the different pulse widths represent coded data. This is the most common modulation method used today due to its high accuracy (< 100 ns at the port). An example of a DCLS signal is shown by the yellow trace in figure 2.

1. **Amplitude Modulated (AM)** – modulated with a 1 kHz sine wave carrier signal with a 3:1 ratio, this signal has no DC content. This made AM popular in the past as it allowed the signal to be transmitted over long distances. Due to the low signal accuracy (< 2 microseconds at the port) AM is no longer the signal of choice. An example of an AM IRIG-B signal can be seen on the green trace in figure 2.
2. **Modified Manchester Modulation** – Modified Manchester modulation is the least common modulation type for IRIG-B. Using a 1 kHz square wave with phase modulation rather than DC level shift, this signal contains no DC bias. This allows for transmission over long distances, while maintaining a high accuracy (<100 ns).

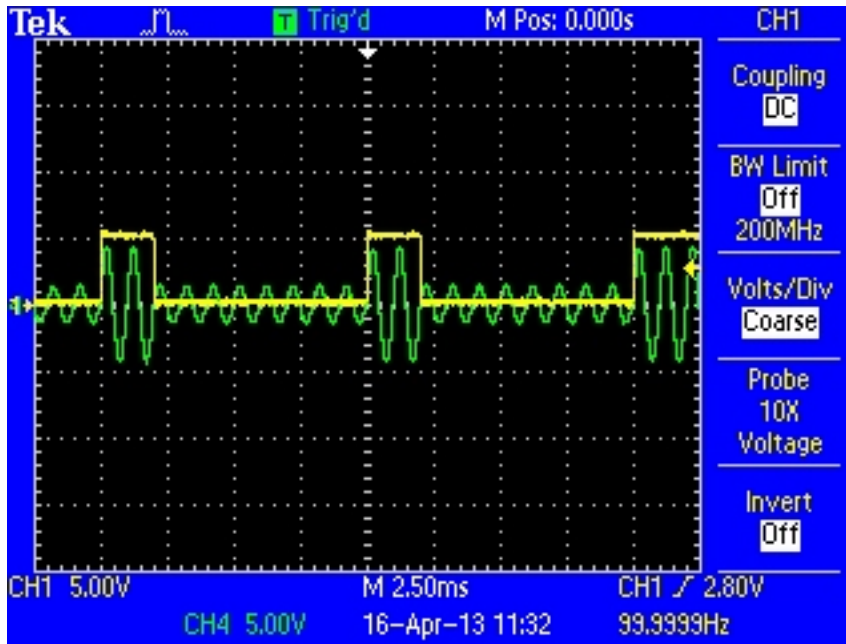

Figure 2 – Comparison between AM IRIG-B and DCLS IRIG-B

The accuracy and transmission characteristics of each modulation type are summarised in table 2.

Table 2 – Modulation properties for IRIG-B

	Modulation Type	Maximum Transmission Distance	Accuracy (at clock port)
0	DCLS	< 100 m	< 100 ns
1	AM	< 300 m	< 2 μ
2	Modified Manchester	< 300 m	< 100 ns

The number in front of these modulation types (0,1,2) make up the IRIG-B format code, which is generally presented as IRIG-Bxyz or Bxyz. In this code x is the modulation type, y is the carrier frequency and z is the coded expressions or information that is included within the IRIG message.

To make up the full expression, we must now look at the different options for the carrier frequency and the coded expression.

### Carrier Frequency:

For IRIG-B, the carrier frequency will depend on the modulation type that is being used. For example, in the case of a DCLS modulation there is no carrier wave form, therefore there is no carrier frequency.

In the case of the AM there is a 1 kHz sine wave used to transmit the signal over extended distances. The two common carriers in IRIG-B are:

- a) **No carrier** – DCLS requires no carrier frequency
2. **1 kHz carrier** – AM and Modified Manchester both commonly use a 1 kHz carrier

The three common IRIG-B formats are therefore:

- **IRIG-B00z** – This is a DCLS IRIG-B signal with no carrier.
- **IRIG-B12z** – This is an amplitude modulated (AM) signal with a 1 kHz carrier sine wave
- **IRIG-B22x** – This is the modified Manchester modulation type with a 1 kHz square wave carrier

The final section of the IRIG-B code to consider is the Coded Expressions, also thought of as the information contained in the signal.

### Coded Expressions:

To understand the different coded expressions we must first define the acronyms used in IRIG-B. These are listed and defined in table 3.

**Table 3 – Acronym definitions for IRIG-B Coded Expressions**

Acronym	Name	Definition
BCD <sub>TOY</sub>	Binary coded Decimal <sub>Time of Year</sub>	BCD <sub>TOY</sub> contains the following information; seconds, minutes, hours, day of year
BCD <sub>YEAR</sub>	Binary Coded Decimal <sub>Year</sub>	BCD <sub>YEAR</sub> contains the year value (0-99)
CF	Control Function	Control functions are a blank section of the IRIG-B code that can be filled with user defined control fields. More about this in the extensions section
SBS	Straight Binary Seconds	SBS counts from 0 to 86,399. This is the number of seconds that have passed during the day. This can be used to get time of day also, and is sometimes used as a check.

With an understanding of the different acronyms, we can now look at the seven data options available to make up the IRIG-B time code. The options are listed in table 4.

Table 4 – IRIG-B Coded Expressions

Code	Expression	Details
0	BCD <sub>TOY</sub> , CF, SBS	Seconds, Minutes, Hours, Day of Year, Control functions & Straight binary seconds
1	BCD <sub>TOY</sub> , CF	Seconds, Minutes, Hours, Day of Year & Control functions
2	BCD <sub>TOY</sub>	Seconds, Minutes, Hours & Day of Year
3	BCD <sub>TOY</sub> , SBS	Seconds, Minutes, Hours, Day of Year, & Straight binary seconds
4	BCD <sub>TOY</sub> , BCD <sub>YEAR</sub> , CF, SBS	Contains; Seconds, Minutes, Hours, Day of Year, Year, Control functions & Straight binary seconds
5	BCD <sub>TOY</sub> , BCD <sub>YEAR</sub> , CF	Contains; Seconds, Minutes, Hours, Day of Year, Year & Control functions
6	BCD <sub>TOY</sub> , BCD <sub>YEAR</sub>	Contains; Seconds, Minutes, Hours, Day of Year & Year
7	BCD <sub>TOY</sub> , BCD <sub>YEAR</sub> , SBS	Contains; Seconds, Minutes, Hours, Day of Year, Year & Straight binary seconds

The most common option for each of these expressions is code 4, which contains all the timing information and control fields. This will ensure that no matter what device you are using, it can receive the information that it requires to sync to the master clock. For the devices that do not need the extra information, this **should** be discarded by the slave device.

This the brings up to the complete IRIG-B formats;

- **IRIG-B004<sup>1</sup>** – This is a DCLS IRIG-B signal with no carrier.
- **IRIG-B124** – This is an amplitude modulated (AM) signal with a 1 kHz carrier sine wave
- **IRIG-B224** – This is the modified Manchester modulation type with a 1 kHz square wave carrier

Now, if you are looking for a quick reference guide to all this information, please refer to figure 3. This perfectly summarises all the options available in the IRIG range.

---

<sup>1</sup> So far we have referred to the B004 code as only being transmitted over a DC signal. It is important to note that the same format also applied to IRIG-B over a fibre optic signal.



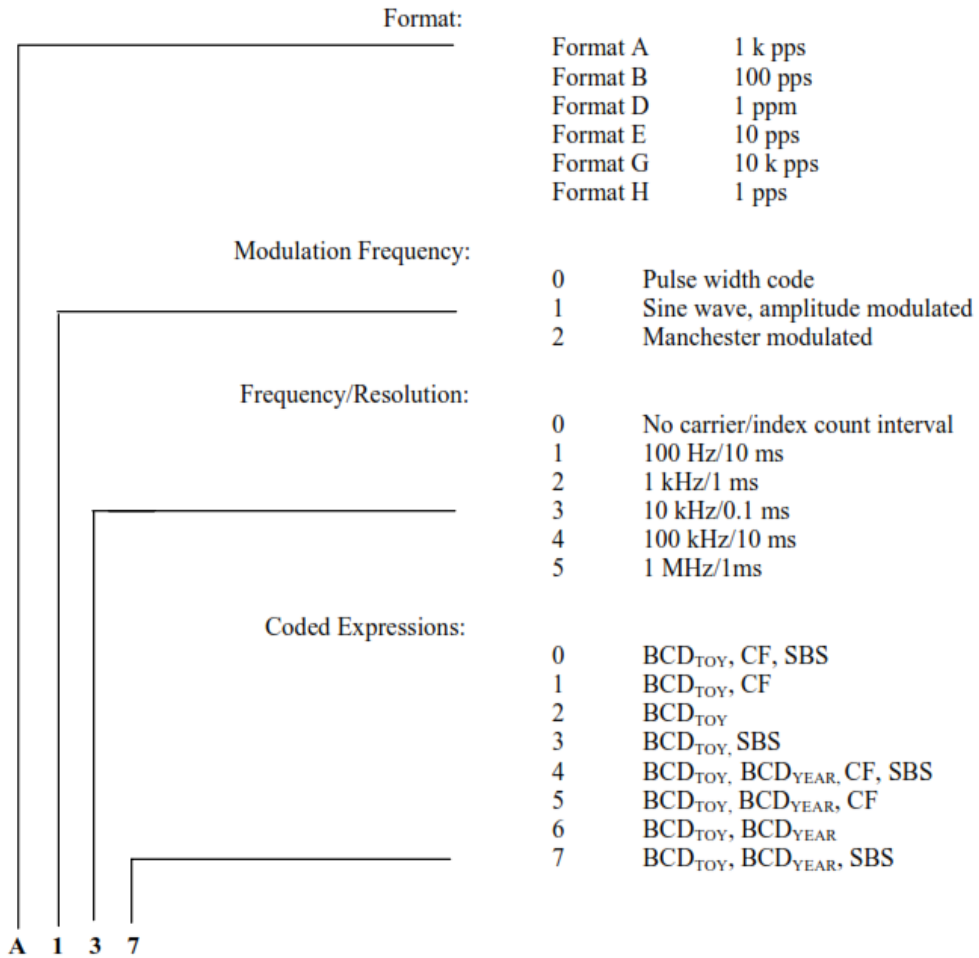

Figure 3 – IRIG Code Reference Guide sourced from IRIG Standard 200-04

## IRIG-B Signal – Key Properties

The physical IRIG-B signal is made up of several key properties. It is not essential to know the properties, but it does help in the overall understanding of how the timing signal works. It's also useful if you ever have to look at an IRIG-B signal on an oscilloscope (use an [IRIG-B analyser](#) – it's a lot easier!)

The first point we are interested in is the reference marker which is found at the start of the signal. In the case of a DCLS signal, this reference marker is an 8 ms pulse which has its rising edge at the on second mark (when the second starts). This 8 ms pulse marks the start of the IRIG-B code, and gives a second pulse reference for slave equipment to align to.

The easiest way to find the on-time reference marker is to look for the two 8 ms pulses which are side by side. The first is the end of the trailing IRIG-B frame, and the second is the on-time marker starting the new IRIG-B frame. An example of this pulse is shown in figure 4.

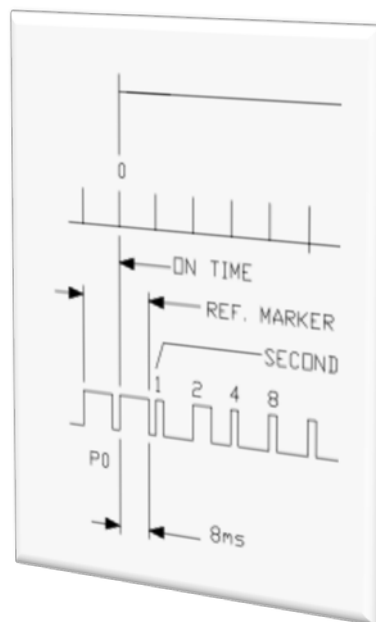

Figure 4 – 8 ms reference marker shows the start of the IRIG-B frame. Sourced from IRIG Standard 200-04

From the reference marker come the binary coded decimals which are split into ten 8-bit groups, each divided by 8 ms position identifiers (P1 to P0). The data contained in these blocks are coded using different pulse widths to represent either a binary 0 or a binary 1. In referring to figure 5, you will note that a binary 0 is represented by a 2 ms pulse, and a binary 1 by a 5 ms pulse.

Taking all the bits between the position identifiers, you can convert binary to a decimal value to get the correct time and date!

Please note that the seconds, minutes, hours and year field are broken into two 4-bit sections. The first four bits represent decimals 0-9 with the next four bits representing the 10's of that number i.e. 10's of seconds – 0, 10, 20, 30, 40, 50. Please refer to table 5 for the full details.



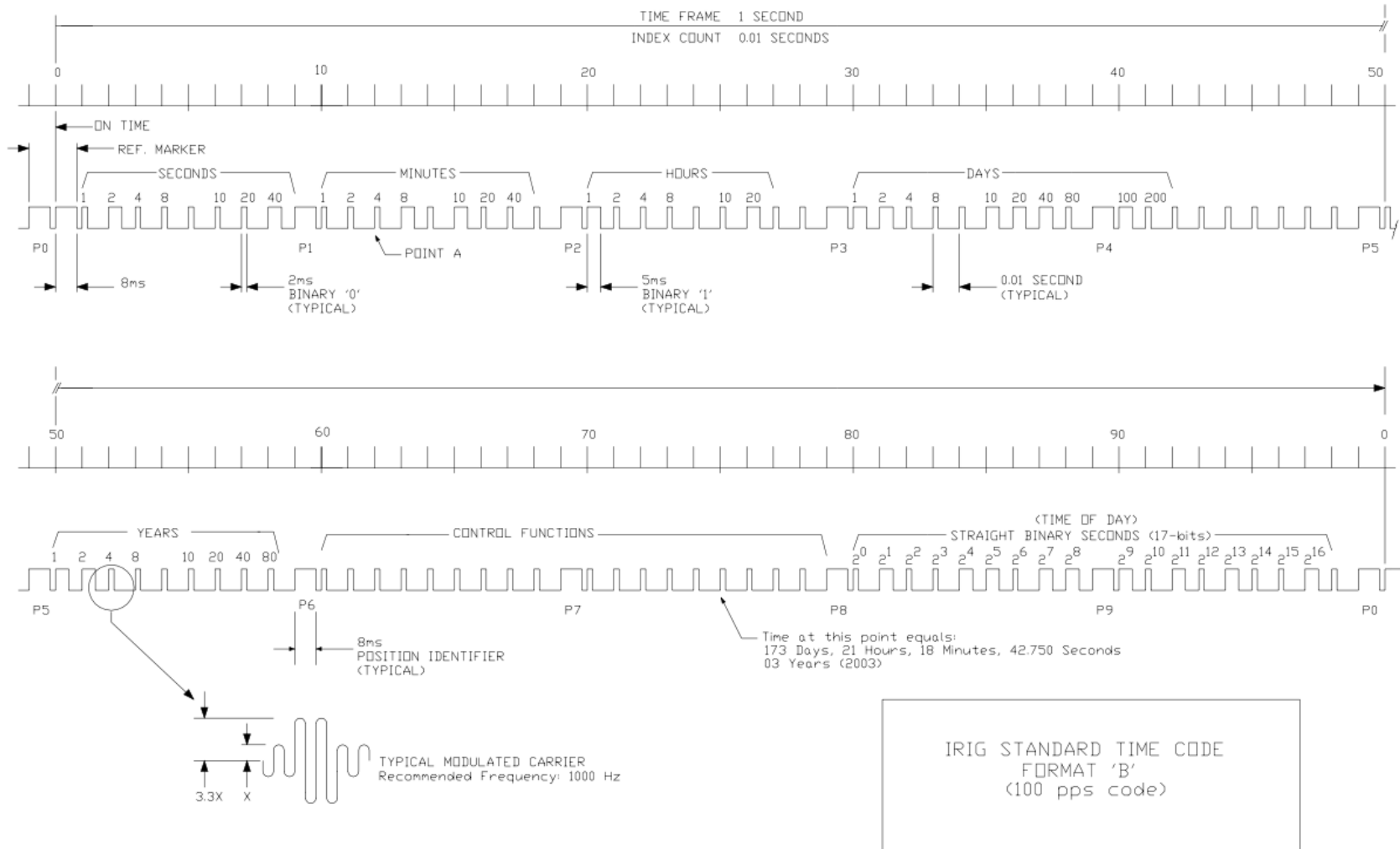

Figure 5 – Complete IRIG-B signal with data listed. Sourced from IRIG Standard 200-04

Table 5 – Break down of IRIG-B Data vs Bit Number. Data from IRIG Standard 200-04 and Wikipedia

Bit#	Value	Definition	Bit#	Value	Definition	Bit#	Value	Definition	Bit#	Value	Definition	Bit#	Value	Definition						
0	P <sub>r</sub> - Ref Mark		20	1	Hours (0-23)	40	100	Day of year (1-366)	60	0	Control Functions	80	1	Straight Binary Seconds (0-86399)						
1	1	Seconds (0-59)	21	2		41	200		Unused	61		0	81		2					
2	2		22	4		42	Unused	62		0		82	4							
3	4		23	8		43		Unused		63		0	83		8					
4	8		24	Unused		44				Unused		64	0		84	16				
5	Unused		25	10		45						Unused	65		0	85	32			
6	10		26	20		46							Unused		66	0	86	64		
7	20		27	Unused		47									Unused	67	0	87	128	
8	40		28		Unused	48					Unused					68	0	88	256	
9	P <sub>1</sub> - Position ID		29	P <sub>3</sub> - Position ID		49			P <sub>5</sub> - Position ID							69	P <sub>7</sub> - Position ID		89	P <sub>9</sub>
10	1	Minutes (0-59)	30	1	Day of year (1-366)	50	1		Year (0-99)							70	0	Control Functions	90	512
11	2		31	2		51	2	71								0	91		1024	
12	4		32	4		52	4	72		0						92	2048			
13	8		33	8		53	8	73		0		93				4096				
14	Unused		34	Unused		54	Unused	74		0		94	8192							
15	10		35	10		55	10	75		0		95	16384							
16	20		36	20		56	20	76		0	96	32768								
17	40		37	40		57	40	77		0	97	65536								
18	Unused		38	80	58	80	78	0	98	Unused										
19	P <sub>2</sub> - Position ID		39	P <sub>4</sub> - Position ID		59	P <sub>6</sub> - Position ID		79	P <sub>8</sub> - Position ID		99	P <sub>0</sub> - Position ID							

## Control Functions

Within the IRIG-B signal, there are 16 bits available for user defined bits which are outside of the IRIG standard. These control functions can contain several key fields which can tell you the health of the clock, if a leap second is pending, or the daylight savings offset. The two key standards that define what these control bits should be are the AFNOR standard and the C37.118.1 Standard. Let's look at what each of the standards offer in terms of control bits.

### AFNOR NFS 87-500 Extensions

The AFNOR standard is a French standard that is very similar to the IRIG-B code, with additional information about the day of week, month and day of month.

Even though not widely adopted in the power industry, this standard is still supported by most clock vendors.

Figure 6 shows the makeup of the AFNOR signal, with the extra fields added.

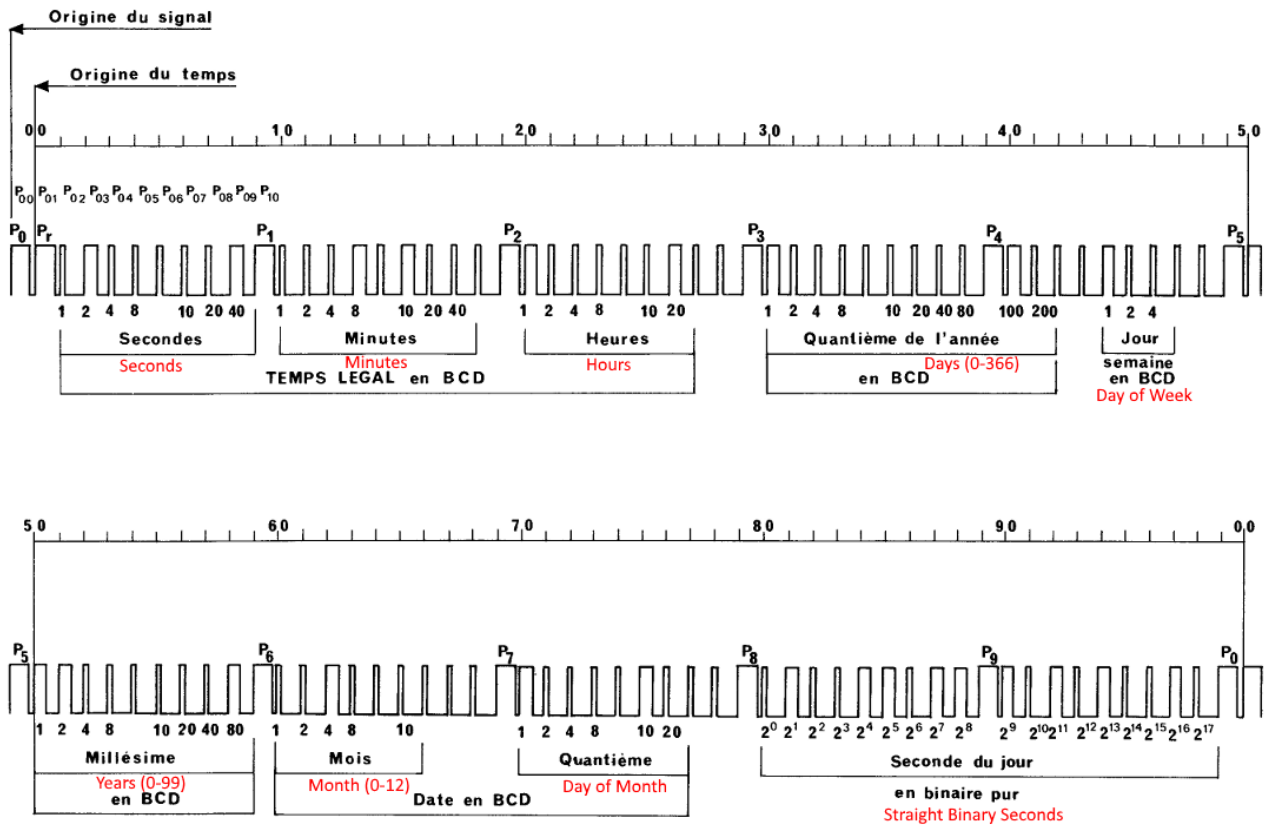

Figure 6 – IRIG-B code with AFNOR enabled. Sourced from AFNOR NFS 87-500 Standard.

### C37.118.1 (superseded IEEE 1344 & C37.118) Extensions

The IEEE C37.118.1 standard for Synchrophasor Measurements for Power Systems was released in 2011, superseding the previous standard C37.118 (2005) and the IEEE 1344 (1995) standards. Each of these standards were released and improved to keep up with the need for real time monitoring of parameters such as current, frequency, load, voltage and so on to avoid blackouts. With the introduction of Phasor Measurement Units (PMUs), the need for high accuracy, reliable time stamping became a strict requirement when recording and comparing samples. Timing errors between two locations due to an unsynchronised clock could result in false tripping, causing operators to make incorrect and potentially costly decisions.

With IRIG-B being a one-way signal, i.e. no feedback to the clock from the slave, additional fields needed to be added to the IRIG-B code to allow the slave devices to decide if the timing source meets their accuracy requirements, and to stop operating if the reported accuracy was too low. This brought about the use of the control fields by the IEEE standards, with the fields in table 6 being added to the signal.

Table 6 – Overview of the control bits added in the IEEE specifications

Bit#	Value	Definition
60	0	<b>Leap Second Pending (LSP)</b> – This field becomes a 1 up to 59 seconds BEFORE a leap is inserted/ deleted. Returns to 0 after the event.
61	0	<b>Leap Second (LS)</b> – 0 = Add a Second (most common) and 1 = Subtract a Second
62	0	<b>Daylight Saving Pending (DSP)</b> – This field becomes a 1 up to 59 seconds BEFORE a DST event. Returns to 0 after the event.
63	0	<b>Daylight Savings Time (DST)</b> – Becomes 1 during DST.
64	0	<b>Time Offset sign</b> – 0 = + and 1 = -
65	1	<b>Time Offset</b> - This is the offset from the IRIG-B time to UTC time i.e. the local time offset (+12 hr for NZ). Taking this offset, and the IRIG time you can get the UTC time. i.e IRIG time – 12 hr = UTC time
66	2	
67	4	
68	8	
69	P <sub>7</sub> - Position ID	
70	0	<b>Time offset 0.5 hours</b> – 0 = No offset and 1 = 0.5-hour offset
71	1	<b>Time Quality bit</b> – this is a 4-bit code representation of the approximate clock time error from UTC. Refer to table 7 for the full range of values.
72	2	
73	4	
74	8	
75	0	<b>Parity</b> – this is the parity for all of the proceeding bits. Acts as a check to ensure the data (SBS and CF) make sense. This will toggle between ODD and EVEN every second.
76	1	<b>Continuous Time Quality</b> - This is a 3-bit code representation of the estimated time error in the transmitted message. Refer to table 8 for the full range of values.
77	2	
78	4	
79	P <sub>8</sub> - Position ID	

## Time Quality (TQ)

The TQ field gives an indication of the time accuracy of the IRIG-B signal at the “on time” point relative to UTC. When in a locked state this value remains at 0, and will only change when the clock loses lock with the satellite constellations, entering holdover.

**Table 7 - Definition of the values available in the TQ field**

Value	Definition
0	Clock is locked to a UTC traceable source
1	Time is within <1ns of UTC
2	Time is within < 10ns of UTC
3	Time is within < 100ns of UTC
4	Time is within < 1µs of UTC
5	Time is within < 10µs of UTC
6	Time is within < 100µs of UTC
7	Time is within < 1ms of UTC
8	Time is within < 10ms of UTC
9	Time is within < 100ms of UTC
10	Time is within < 1s of UTC
11	Time is within < 10s of UTC
15	Fault – Clock failure, time is not reliable

## Continuous Time Quality (CTQ)

The CTQ field gives an indication of the time accuracy of the IRIG-B signal at the “on time” with respect to UTC for each IRIG-B message. CTQ was added to the IRIG-B signal to give an indication of accuracy when in sync as the Time Quality Indicator always shows 0 when in sync.

This field was not available in the IEE1344 standard, being added to the later C37.118 standard. A full table of the available values is shown in table 8.

**Table 8 – Definition of the values available in the CTQ field**

Value	Definition
0	Not used (indicates code from previous version of standard)
1	Estimated maximum time error < 100 ns
2	Estimated maximum time error < 1µs
3	Estimated maximum time error < 10µs
4	Estimated maximum time error < 100µs
5	Estimated maximum time error < 1ms
6	Estimated maximum time error < 10ms
7	Estimated maximum time error > 10mS or time error unknown

## Installation Recommendations

When installing and designing an IRIG-B network, there are a range of factors that need to be considered.

### Cable type – Shielded Twisted Pair (STP) vs Coaxial

The most common implementations of IRIG-B throughout the world use coaxial cable as the transmission medium. Generally, RG58 cabling is used to carry both AM and DCLS signals, as it is easy to wire, easy to clip on termination resistors and has good shielding characteristics.

The next most common is to use shielded twisted pair (STP) cabling like that found in a standard Ethernet cable – except with a braided shield around the outside of the cable. Shielded twisted pair has several benefits including high transmission rates, good shielding characteristics (especially with balanced pairs) and low capacitance characteristics.

In the case of the transmission of IRIG-B, which one is better?

The answer - STP, but why?

The key reason as to why STP is better than coax, is the lower cable capacitance.

For a DCLS signal being transmitted over a long distance the cable capacitance becomes important, as a high capacitance will cause the signals edges to become rounded. Referring to figure 7, the effects of a high cable capacitance can be seen with the rising and falling edges of the IRIG-B signal starting to become rounded. This rounding not only affects the signals accuracy, but may also cause some IEDs to falsely trip, or to reject the signal completely.

The increased cable capacitance also limits the overall distance that you can transmit the signal before needing to regenerate this. In the case of RG58 cabling, it is recommended that distances greater than 50 m have a signal repeater installed to regenerate the signal. For STP this distance increases to up to 100 m before regeneration is required.

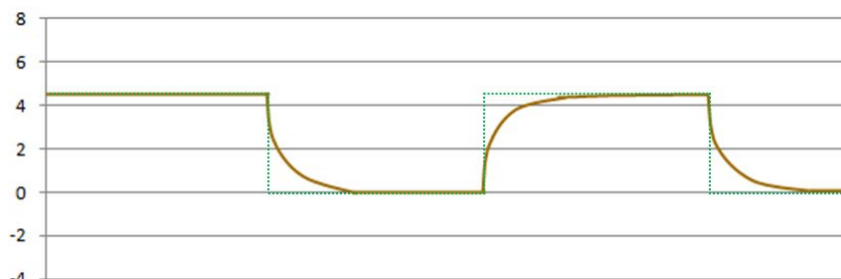

Figure 7 – Signal rounding caused by the capacitance of a coaxial cable

## Terminating Resistor

### a) DC Level Shift (DCLS)

When installing an IRIG-B run, always install a terminating resistor at the end of the cable run. Adding a terminating resistor to the end of the line helps dampen overshoot for high drive lines and reduces signal noise. The effects of an unterminated line can be seen here:

Figure 8 – Un Terminated line vs a Terminate Line

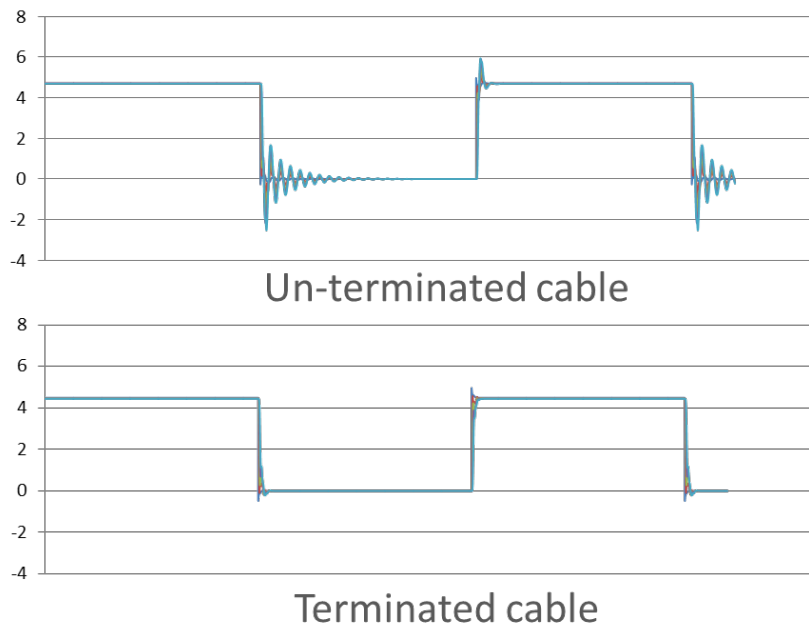

Selecting a termination resistor for a DCLS cable run is quite simple, you just need to match the resistor to the impedance of the cable.

For a shielded twisted pair cabling, the cable impedance is usually 120 Ω (e.g. Belden 9841). For coaxial cable it will depend on what type of cable you use, as to the terminating resistor. For RG58 you would expect to use a 50 Ω terminating resistor, and for RG59 a 75 Ω resistor.

When selecting a resistor you will also need to consider the power rating. As DCLS is generally a 5 Vdc signal, you can calculate the power rating easily using  $Power = \frac{Voltage^2}{Resistance}$ . Resistors above a 0.5 W rating in the E24 (5%) range will cover most requirements.

Remember to take the terminating resistor into account when calculating the bus loading, to ensure you do not overload an IRIG-B output.

### b) AM IRIG-B

Selecting a terminating resistor for AM IRIG-B is slightly different to that of a DCLS signal. It's better to think of the terminating resistor as a voltage divider, which is used to match the line voltage to the input requirements of the slave devices.



To explain this, let's work through an example calculation! Starting by looking at figure 9, you can see that the terminating resistor is attached across the line, at the end of the IRIG-B bus. By attaching it here it's effectively creating a divider for which the ratio is defined by the total resistance of the line, as well as the clocks' internal resistance.

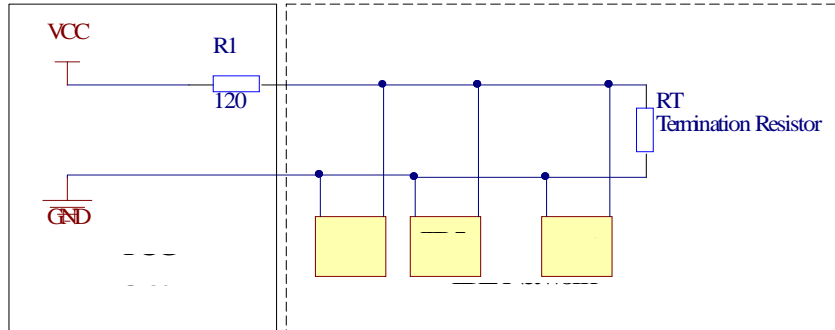

Figure 9 – Example implementation for a termination resistor at the end of an IRIG-B bus.

Before starting this calculation you will need to know the following information:

- 1) The internal impedance of the clock's output.  
In the case of Tekron's range this is 120 Ω
- 2) The input impedance of each IED that is connected to the IRIG-B bus. For most relays this will be in the range of kΩ's. For this example we are assuming all the relays have a 6 kΩ input impedance. This can be found on most relay manufacturers datasheets.
- 3) The input voltage requirements of the IED's. This is where you need to determine the maximum voltage input that the relay allows. This can be anywhere from 5 Vdc to 10 Vdc. This can be found on most relay manufacturers datasheets.
- 4) The output voltage of the clock. In the case of Tekron this is 8 V<sub>peak to peak</sub>

Now that you have this information, the first step is to calculate the total load on the IRIG-B bus. This can be done by adding together all the input impedances of the slave devices. As they are connected in parallel we would expect the equation to look like this:

$$\frac{1}{R_L} = \frac{1}{R_1} + \frac{1}{R_2} + \frac{1}{R_3} + \frac{1}{R_n}$$

Where:

R<sub>L</sub> is the total calculated load

R<sub>1</sub> to R<sub>n</sub> are the input impedances of the slave devices.

In our example, we have 5 protection relays each with an input impedance of 6 kΩ. This makes our equation:

$$\frac{1}{R_L} = \frac{1}{6000} + \frac{1}{6000} + \frac{1}{6000} + \frac{1}{6000} + \frac{1}{6000} = \frac{5}{6000}$$

Solving for  $R_L$ :

$$R_L = \frac{1}{5/6000} = 1,200$$

Now that we know what  $R_L$  is, we can work out the required terminating resistor by using the following equation:

$$R_{term} = \left( \left[ \frac{R_s * V_{req}}{V_{out} - V_{req}} \right]^{-1} - \frac{1}{R_L} \right)^{-1}$$

Where:

$V_{req}$  is the minimum required voltage for the slave device to operate

$V_{out}$  is the AM IRIG-B output voltage

$R_s$  is the output Impedance of the AM IRIG-B output

$R_L$  is the total calculate load

$R_{term}$  is the value we are solving for, which is the terminating resistor

In this example, we will use the following values:

$V_{req} = 6$  Vdc

$V_{out} = 8$  V<sub>peak to peak</sub>

$R_s = 120 \Omega$

$R_L = 1,200 \Omega$

This gives us the following calculation:

$$R_{term} = \left( \left[ \frac{120 * 6}{8 - 6} \right]^{-1} - \frac{1}{1200} \right)^{-1} = \left( \frac{1}{360} - \frac{1}{1200} \right)^{-1}$$

$$R_{term} = \left( \frac{10}{3600} - \frac{3}{3600} \right)^{-1} = \left( \frac{7}{3600} \right)^{-1}$$

$$R_{term} = \frac{1}{0.001944} = 514.3 \Omega$$

From the E24 resistor range, the closest match is a 510  $\Omega$  resistor which will be sufficient to achieve the required voltage level.

## IRIG-B00X Loading Recommendations

A question that is commonly asked is “how many Intelligent Electronic Devices (IEDs) can a single DCLS output drive”? This question is almost always answered with “well it depends on the IEDs and the loading...”

So, how do you calculate how many devices can be run off a single output?

You first need to know the following information:

- What is the drive power of the clocks output? For Tekron this is commonly 150 mA
- What is the input impedance of the IED? Or what is the current drain of the IED? These parameters should be available in the vendors datasheets.
- The distance between the 1<sup>st</sup> IED and the last IED that you want to synchronise.

Once you have this information the calculation is quite simple.

To show how to do this calculation, we will work through an example and apply the following equation:

$$I_L = I_1 + I_2 + I_3 + I_n + \left( \frac{V_s}{R_{term}} \right)$$

Where:

$I_L$  is the total current load

$I_1$  to  $I_n$  is the current drain of each IED on the IRIG-B bus

$V_s$  is the supply voltage from the clock (typically 5 Vdc)

$R_{term}$  is the terminating resistor which matches the cable impedance (120  $\Omega$  for shielded twisted pair cabling)

The first step to starting this calculation is to know what load each IED is going to put on the IRIG-B line. This is different for each manufacturer.

To find this data, you will need to look in the datasheet of the IED for the IRIG-B or time sync section. Here you will generally find the input voltage range (5 Vdc) and either the input impedance (k $\Omega$ s) or the current load (mA).

If the datasheet is nice enough to have the load current, this is your  $I_1$  value. If it only gives you the input impedance you can calculate the current load using:

$$I = \frac{V}{R}$$

Where

V is the source voltage (5 Vdc)

R is the input impedance of the IED

For this example, we will use 25 protection relays with an input impedance of 5 k $\Omega$ .

This would mean that each IED has a current burden of:

$$I_1 = \frac{5}{5,000} = 1 \text{ mA}$$

Across 25 relays this would come to a total of 25 mA loading.

This then brings us to the main equation:

$$I_L = 25 + \left(\frac{5}{120}\right) = 77 \text{ mA}$$

Great! Now we know the total loading of the relays on the IRIG-B output. The next point is to check that this  $I_L$  is not larger than the clocks drive power. As Tekron's devices supply a 150 mA drive power, this leaves 73 mA to spare!

Great, so does this mean I can add another 70 relays to this IRIG-B line?

Yes, technically you can add a further 70 relays to this output, but first you need to consider the total cable length between the clock and the last relay. If the cable length is getting greater than 50 m it's recommended that you either split the remaining relays off onto another output, or use a [signal repeater](#) to regenerate this signal.

There are several reasons for this suggestion. The first is that after 50 m of transmission, the square IRIG-B signal may start to show rounded edges as the cable capacitance starts to degrade the signal quality. It may even start to degrade to a point where IEDs will reject it as a valid signal, or the signal accuracy will decrease due to the rounded rising and falling signal edges.

To correct this issue you can install a [simple signal repeater](#) to regenerate the signal, giving much sharper rising and falling edges, filtering out the noise, and adding in an isolation barrier.

The second point to think about is the accumulated propagation delay of the signal as it passes down a long piece of wire. For Belden 9841 shielded twisted pair cabling the propagation delay is 5.25 ns/ m. Over 50 m this adds to 262.5 ns of delay. For most applications this is minimal, especially when your target accuracy is only 1 ms. But in an application where you are aiming for a < 1  $\mu$ s accuracy, this is important as you could lose 26% of your overhead just in the cable transmission delay.

## IRIG-B12X Loading Recommendations

AM IRIG-B follows a different concept to that of DCLS IRIG-B. As AM IRIG-B does not contain a DC bias, current draw is no longer an issue – but voltage drop is.

In the case of the example where 25 IEDs are connected to a bus, the key concern will now become the input voltage requirements for the IEDs compared to the line voltage supplied from the clock.

Using the equation in the terminating resistor section, you will need to determine the voltage level which all the IEDs will accept, and then work through the equation to determine the best voltage divider to reach that.

You will need to take into consideration your accuracy targets, and factor in the propagation delay which is induced from the cable.

As this is a modulated signal with no DC bias, it is more immune to noise and can therefore be transmitted up to 300 m without requiring a repeater device.

## Fibre Installations

When transmitting an IRIG-B signal over a long distance or through a high noise environment (EMI), a DCLS or AM IRIG-B signal may not be the best option. This is when IRIG-B over a fibre multimode link makes sense.

There are many advantages to using a fibre connection. Some of these are:

- **Perfect isolation** – using a fibre link between a clock and a IED or [media converter](#) gives an isolation barrier which protects both devices, should one enter a fault state.
- **Long transmission distances** – using a multimode fibre link you can transmit a signal up to 1 kilometre without the need for repeaters.
- **Immune to Radiated noise** – DCLS is a 5 Vdc signal which is quite susceptible to external noise. Using a fibre link you remove these concerns as electrical noise will not affect it.

There are however some downsides to using fibre, which include:

- **Point to Point connection** – If you have hundreds of IEDs that require IRIG-B, you now need a range of [distribution units](#) to split a single fibre output into many outputs. This gives perfect isolation, but my increase the cost of the installation.
- **Daisy chained links** – when using fibre across multiple IEDs, you need to daisy chain (series connection) all the devices. If a single device fails there is potential for all the downstream devices to lose sync.

Perhaps the best way to use fibre in a typical substation is to have all connections external to a cabinet/ panel completed via a fibre link. Using cost effective [media converters](#), you can then convert this fibre signal back into a DCLS or AM IRIG-B signal and keep these low voltage signals local to the cabinet. This gives perfect isolation between the panels, removes the concerns around emitted noise, and removes many concerns around the transmission distances (don't forget about propagation delay). This gives users the best of both transmission mediums.

## Programmable Pulses

Programmable pulses are another common timing signal which is supplied by almost all GPS clocks. Programmable pulses are a logic high (or low) pulse that has a programmable period and duration. These pulses can range from 1000 pulses per second to one pulse per second, minute, hour, day and so on.

Most equipment that use pulses will require a pulse per second (PPS) with a duration of 100 ms. PPS signals are used to increase the accuracy of other timing protocols such as SNTP/NTP and ASCII strings, as they align the equipment's internal counter with the on time point of the new second or the starting point of the new second. These pulses contain no time or date data.

Transmitted via fibre or STP, pulses are generally highly accurate, with most leaving the clock's port with an accuracy of < 100 ns to UTC.

Commonly, pulses are a 5 Vdc signal, but can range up to 24 Vdc depending on the application. Pulses are still widely used today and act as a common reference for many pieces of equipment.

## Summary

IRIG-B is one of the most common timing signals used in the power industry to date. It is used to time both critical and non-critical applications by providing an accurate time source to all connected devices, and is likely to remain the key timing protocol for years to come. IRIG-B is not a perfect timing protocol and as discussed requires care when deploying in the field to ensure a trouble-free installation.

If you are ever in doubt or have questions about deploying IRIG-B in your installation, we recommend that you contact Tekron or one of our industry partners.

[www.tekron.com](http://www.tekron.com)

+64 4 566 7722

[info@tekron.com](mailto:info@tekron.com)

Tekron International Limited  
Level 1, 47 The Esplanade  
Lower Hutt 5012  
New Zealand